

music hall

mmf-7.1

INSTRUCTION MANUAL

music hall

<http://www.musicchallaudio.com>

august 2007

CONGRATULATIONS ON YOUR PURCHASE

You have selected an exceptional turntable. Each component used in the construction of the mmf-7.1 was selected to provide you with superior performance and the highest level of sound reproduction available today. We know of no turntable that costs as much to produce yet sells for so little. The precise and elegant design of this turntable makes it easy to install and operate. Please take a few moments to read over the operating instructions to ensure that you get the best performance from your turntable and years of trouble-free service.

SAFETY GUIDELINES

This product is designed and manufactured to strict quality and safety standards. However, you should be aware of the following installation and operation precautions:

1. Take heed of warnings and instructions

Read all the instructions before connecting or operating the turntable. Keep this manual so you can refer to these safety instructions. Heed all warnings and safety information in these instructions and on the turntable. Follow all operating instructions.

2. Water and Moisture

To reduce the risk of fire or electric shock, do not expose the turntable to moisture or water. If the turntable is exposed to moisture, immediately disconnect the power cord from the wall. Take the deck to an authorized music hall service center for inspection. Do not touch the turntable, power cord, or plug with wet hands.

3. Object or liquid entry

Do not allow foreign objects or liquids into the unit. If this happens, immediately disconnect the power cord from the wall and take the unit to an authorized music hall service center for inspection.

4. Heat

Keep the turntable away from naked flames, radiators, heat registers, stoves, or any other heat-producing appliances (including amplifiers).

5. Climate

The turntable has been designed for use in moderate climates. Do not attempt to use below 41 degrees Fahrenheit (5 degrees Celsius) or above 95 degrees Fahrenheit (35 degrees Celsius).

6. Racks and Stands

Place the turntable on a fixed, level surface strong enough to support its weight. Do not place it on a moveable cart that could tip over. We recommend only using stands approved for use with audio equipment. See the **SITING** section for further suggestions.

7. Cleaning

Please refer to the **MAINTENANCE** section for detailed cleaning instructions.

8. Power Sources

Connect the turntable only to a power supply of the type and voltage described in the operating instructions or specified on the rear panel of the unit.

9. Power-cord protection

Connect the turntable to the power outlet only with the cord supplied. Do not modify the supplied cable in any way. Do not attempt to defeat grounding and/or polarization provisions.

Do not use extension cords.

Do not route the power cord where it will be crushed, pinched, bent at severe angles, exposed to heat, or damaged in any way.

10. Non-use periods

If the deck is to be left unused for a long period of time, the power cord should be unplugged from the wall outlet and the belt removed.

11. Damage Requiring Service

Stop using the turntable immediately and have it inspected by an authorized music hall service center whenever:

1. The power supply cord or plug has been damaged.
2. Liquid has been spilled onto the motor or into the bearing well.
3. The turntable has been exposed to rain.
4. The turntable does not operate properly.
5. The turntable has been dropped or damaged.
6. Smoke or any unusual smell is detected from the turntable.

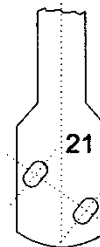
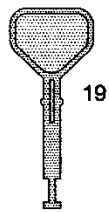
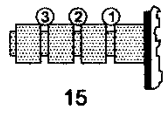
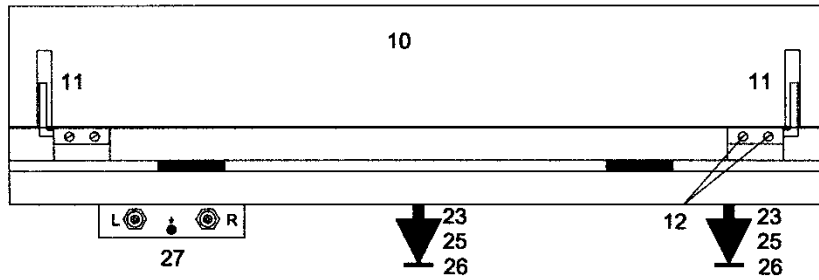
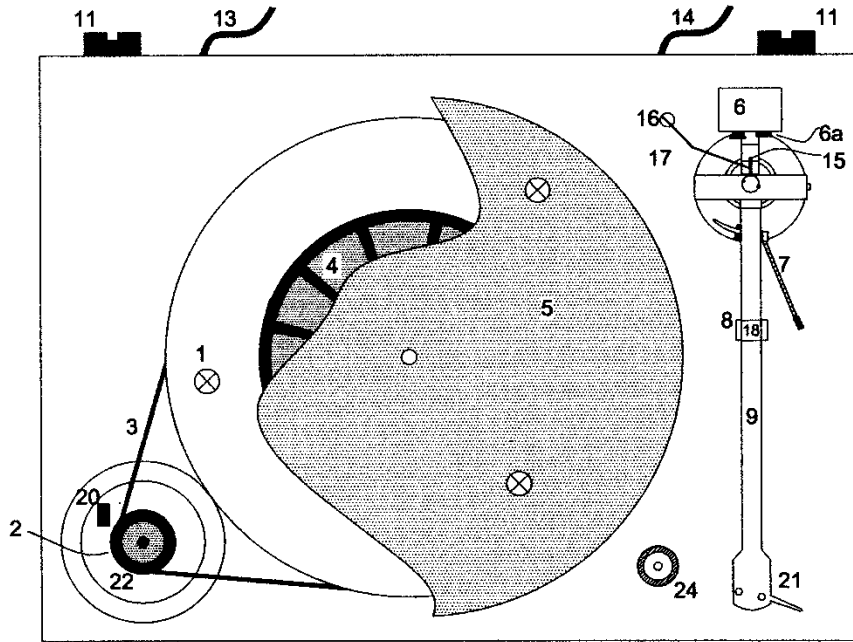

PARTS INVENTORY AND OPERATION CONTROL DIAGRAM

1. 3 x removable transport screws
2. 1 x stepped motor pulley
3. 1 x drive belt (packaged in parts bag)
4. 1 x sub-platter
5. 1 x platter with felt mat (packaged in bottom of box)
6. 1 x tonearm counterweight (located in packing material)
7. 1 x tonearm lift lever/cueing lever
8. 1 x tonearm rest
9. 1 x tonearm
10. 1 x dust cover
11. 2 x dust-cover hinges
12. 4 x dust-cover hinge screws
13. 1 x mains cable connected to wall transformer
14. 1 x removable high quality interconnect cable (included in parts bag)
15. 1 x anti-skating rod
16. 1 x anti-skating weight (packaged in parts bag)
17. 1 x anti-skating hanger
18. 1 x removable tonearm-locking strap (red plastic)
19. 1 x belt changing tool (packaged in parts bag)
20. 1 x on/off switch
21. 1 x head shell fitted with Goldring Eroica H (high output moving-coil cartridge)
22. 1 x motor
23. 3 x threaded screws
24. bubble level
25. adjustable spiked feet
26. spike protectors
27. turntable output connectors

Parts bag includes:

- 1pr. x white gloves
- 1 x 45 rpm adapter
- 1 x drive belt (3)
- 1 x anti-skate weight (16) (tiny weight attached to small piece of fishing line)
- 1 x belt changing tool (19)
- 1 x Allen key to adjust arm lift
- 1 x Allen key to adjust VTA (this one has a slight bend in it)
- 1 x record clamp
- 1 x high quality interconnect cable (14)
- 3 x adjustable spiked feet (25)
- 4 x spike protectors (26) (flat dime looking object that spike sits on)
- 1 x cartridge alignment guide
- 1 x instruction manual

GETTING STARTED

Thank you for purchasing the music hall mmf-7.1 turntable. The music hall mmf-7.1 turntable is 2-speed belt-driven, audiophile quality turntable with many unique features. It is constructed using a split-plinth design and features an external motor. The mmf-7.1 comes in a high gloss, black piano lacquer finish.

THE SPLIT-PLINTH.

The plinth has three adjustable spiked feet and comes with a set of small discs (cups). The discs prevent marking of the surface of the supporting shelf. A spirit level is incorporated on the top platform. The two platforms of the plinth are separated by four Sorbothane hemispheres, which act as a suspension and isolation system. External phono sockets are attached to the bottom platform. A high quality interconnect is supplied.

THE MOTOR

The motor is 12 volt AC and comes with an external power supply. The motor rests in a cutout on the front, left quadrant of the turntable. It is completely isolated from the table and sports a blue LED. Placing the motor diagonally opposite the arm reduces any vibrations caused by the belt from entering into the cartridge. Any vibrations would be absorbed along the length of the arm thus bypassing the stylus (The stylus moves from left to right, not front to back).

THE PLATTER

The belt runs round the perimeter of the acrylic platter. Acrylic was chosen for its superior sound quality and isolation properties. A screw-on record clamp and felt mat are supplied as standard.

THE ARM

The tonearm is the 'Project Carbon'. This is a carbon fiber version of the acclaimed Project 9.1 arm. The bearings are made from hardened stainless steel points set in sturdy ring cages. The counterweight's center of gravity is level with the stylus tip. It is decoupled from the arm and acts as a resonance damper. The arm also has adjustable VTA, a damped arm lift and highly flexible internal wiring drawn from high purity copper.

THE CARTRIDGE

The mmf-7.1 comes standard with a Goldring Eroica H, high-output moving-coil cartridge. The Eroica H was chosen for its low mass, high rigidity body, rare earth Neodymium magnet, and its Gyger II line contact stylus. It is a perfect complement to the audiophile qualities of the mmf-7.1. These features combine to ensure that the mmf-7.1 delivers superior audio performance that will provide years of enjoyment.

FOR YOUR INFORMATION

This manual provides valuable information that will help you get optimum performance from your system. Please contact your authorized music hall dealer for any additional clarifications you may require. **Save the music hall mmf-7.1 shipping carton and all enclosed packing material for future use.** Shipping or moving the mmf-7.1 in anything other than the original packing material may result in severe damage that is not covered by the warranty. Be sure to keep the original sales receipt; it is your best record of the date of purchase, which you will need in the event warranty service is required.

SET-UP

The music hall mmf-7.1 is supplied partially disassembled and carefully packaged for safe transport. To assemble the turntable, please follow the instructions carefully.

1. Clear a level (use a spirit level) and suitable workspace to assemble the turntable. This may be the final playing location.
2. Remove and put on white cotton gloves (in large plastic bag)
3. Remove the turntable and all parts from the carton. A short gray piece of plastic pipe will be found underneath the cutout portion of the turntable on top of the motor. This is part of the packing and is not used with the motor or turntable.
4. Screw the three spiked feet (25) (included in parts bag) onto the threaded screws (23) on the bottom of the turntable. 4 x spike protectors (26) (flat dime looking objects that spike sits on) are included. Use them underneath the spikes.
5. Level the turntable by adjusting the spiked feet (25). Use the bubble level (24) for this purpose.
6. Remove the 3 transport screws (1) from the turntable and save for future use.
7. Gather together the 3 motor components (round motor base – found in bottom of box under the Styrofoam, wall transformer – found in small white carton in bottom of box, and motor – found underneath the turntable motor cutout and piece of gray plastic pipe. The short plastic gray pipe is part of the packing material and is not used with the turntable or motor.
8. Place the round motor base underneath the motor cutout on the left front of the turntable. Center the motor base in the cutout.
9. Carefully, ease the motor into the cutout and onto the motor base. Orient the motor so that the socket for connection to the wall transformer is towards the back.
10. Run wire from the wall transformer under the turntable and plug it into the socket on the lower back of the motor.
11. Center the platter (5) over the spindle of the sub-platter (4) and lower it until it rests securely on the sub-platter.
12. Install the drive belt (3) for 33 $\frac{1}{3}$ rpm play. Loop the belt around the smaller diameter rim of the stepped motor pulley (2) and around the rim of the platter (5). (For 45rpm play, use the large diameter rim of the motor pulley).

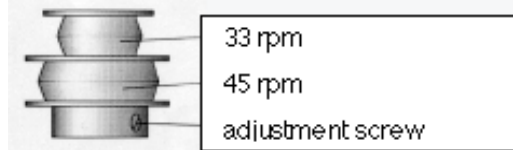

13. Place the counterweight (6) onto the tonearm. To do this, position yourself in front of the turntable. Hold the counterweight so that the numbers are nearer you. Carefully, screw the counterweight counterclockwise onto the back of the tonearm.
14. Remove the tonearm-locking strap (18). Place it in a safe position for possible future transport.
15. Make sure the tonearm is in the tonearm rest (8). Carefully, remove the stylus guard (the piece of clear plastic on the bottom of the cartridge). It slips off of the cartridge by pulling it towards you in a slight downward motion. Save it for future use.
16. You will now set the tracking force. The mmf-7.1 comes complete with a factory installed Goldring Eroica H cartridge. We recommend a tracking force of 1.75g. Please note; the tracking force scale (6a) on the counterweight has no decimal point. 10 on the tracking force scale actually is 1.0 g. 15 is actually 1.5g, etc. 1.75 g is between 17 and 18g on the scale. To set the tracking force you must first balance (zero) the tonearm (9).

The objective of balancing or zeroing the tonearm is to get the tonearm to float parallel to the platter.

First, **lower the cueing lever (7)**.

Using your left hand, lift, position, and hold the tonearm (9) between the tonearm rest (8) and the platter (5). To avoid damage, be careful not to allow the cartridge to contact the plinth (the turntable base).

With your free hand turn the counterweight counterclockwise or clockwise until the tonearm floats freely, without the aid of your hand, in mid-air and parallel to the platter. Don't worry about the number on the tracking force scale, you will soon calibrate and set it properly. Once you have balanced the tonearm, return it to the tonearm rest.

You are now going to set the ring with numbers on the counterweight to zero. This is called the tracking force scale.

The tracking force scale (6a) turns independently of the counterweight.

IMPORTANT

With your right hand hold the rear part of the counterweight to make sure that it does not move.

With your left hand, lightly grip and turn the tracking force scale until the number zero is in the twelve o' clock position (dead center on top of the counterweight).

The tonearm is now zeroed. Check it, by once again floating the tonearm between the tonearm rest and the platter. If the tonearm doesn't float parallel to the platter at zero, return to the previous steps and make the necessary adjustments.

Return the tonearm to the tonearm rest.

IMPORTANT

Do not touch the tracking force scale again.

Turn the counterweight counterclockwise with your right hand.

You will notice that the tracking force scale will also turn.

Turn it through numbers 5, 10, 15 to the position centered between 17 and 18 on the scale). This is equivalent to 1.75 grams. The correct tracking force has now been set.

Every arm and cartridge combination has an optimum tracking force. This can easily be set by ear. Increments of 0.1g can produce significant differences. Once the cartridge has run-in (usually about 24 -50 hours of playing time) feel free to experiment with a slightly higher or lower tracking force and pick the one you prefer.

17. Locate the anti-skating weight (16). You will notice a small fishing line attached to the anti-skating weight (16). Slip the looped end of the fishing line over the anti-skating rod (15) and into notch number 2 (See diagram below). Lift the anti-skating weight (16) over the anti-skating hanger (17) and feed the fishing string through the looped end of the anti-skating hanger (17). The anti-skating weight (16) should now be dangling in free space to the left of the hanger. If it is not dangling, simply bend the anti-skating hanger (17) by pushing it away from the tonearm pillar with your finger.

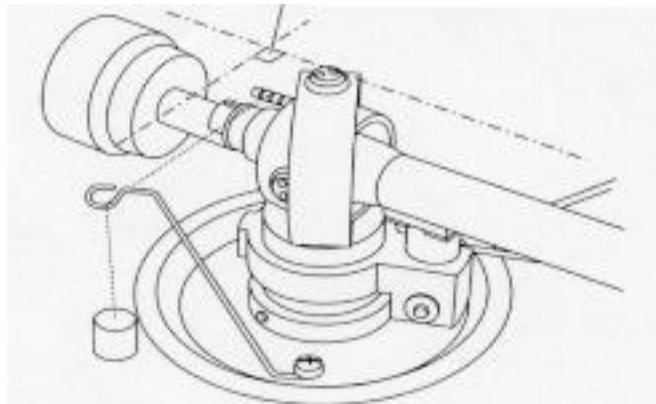

18. Slide the dust cover (10) onto the dust cover hinges (11) on the back of the plinth. If necessary, adjust the tightness of the hinges by turning the dust cover hinge screws (12).

NOTE

If you are substituting another cartridge for the Goldring Eroica, you may need to make the following further adjustments to the tonearm (9) and cartridge:

If you are a novice, music hall recommends getting professional help.

All cartridges with half inch mounting holes can be fitted. Leaving the stylus guard on, fit the cartridge to the head shell (21) using the screws supplied with the cartridge by passing one screw through each slot in the finger lift and the head shell (21). Snug the nuts.

Connect the tonearm (9) wires to the cartridge pins as follows:

white left channel positive (L+)
red right channel pos. (R+)
green right channel return (R -)
blue left channel return (L -)

To achieve the best sound reproduction, the cartridge must be positioned precisely in the head shell. To do this, fit the tangency guide (you'll find this in the parts bag. It's a white rectangular piece of cardboard with black lines) over the spindle at point 'A' and onto the platter, black lines side up (See diagram below). Remove the stylus guard. Move the tonearm (adjusted for the correct tracking force of your cartridge) to the pattern. When the stylus tip of the cartridge is at points 130mm and 240mm, the front of the cartridge should be parallel to the lines on the pattern. If necessary, slide the cartridge back and forth until the stylus tip is positioned correctly. Tighten the cartridge mounting screws.

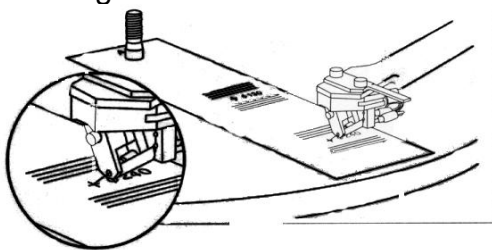

VTA Adjustment: The VTA for the installed Goldring Eroica H cartridge has been properly set at the factory. To adjust the VTA for other cartridges, lay a record on the platter (5). Slacken the horizontal adjustment screws (two **Allen** screws located near the plinth on the back of the tonearm pillar) with the Allen Key provided.

IMPORTANT.

Do not loosen the vertical screws that hold the anti skate arm to the base.

Move the tonearm (9) up or down until it is parallel to the record surface when viewed from the side. Tighten the horizontal adjustment screws.

VTA like Tracking Force can also be set by ear. Feel free to experiment with VTA positions slightly above or below parallel and choose the position you prefer.

If you have any further questions regarding the adjustment of your turntable, please contact your music hall dealer.

Azimuth Adjustment: Azimuth is the angle of the stylus to the record groove. Viewed from head-on, you want the stylus to be perpendicular to the record groove so as to not favor one channel over the other. Keep in mind that azimuth is properly set at the factory and rarely needs to be adjusted. You can check the azimuth by performing a visual inspection. Place the tonearm (9) in the middle of a non-spinning record and look to see that the stylus is perpendicular to the record groove. If it is off to one side or the other, you will need to adjust the azimuth. To adjust azimuth, simply loosen the setscrew located on the top of the tonearm (9) under the anti-skating rod (15). To adjust the setscrew, you will need to first remove the anti-skating rod (15). Start with the tonearm (9) in the tonearm rest (8). Remove the anti-skating weight (16) from the anti-skating rod (15). Hold the anti-skating rod (15) between your thumb and forefinger and unscrew it using a clockwise rotation. Lift the tonearm (9) up about 2 – 3 inches out of the tonearm rest (8). Look carefully on top of the tonearm (9) near the area previously occupied by the anti-skating rod (15). You will see a small setscrew. Slightly loosen this screw. This will loosen the tonearm (9) and allow you to twist it from side to side. Position the tonearm (9) so that the stylus is perpendicular to the record groove. Tighten the setscrew. Replace the anti-skating rod (15) and anti-skating weight (16). Listen. You are listening for a balanced soundstage with the greatest area and depth. You may need to go back and forth a couple of times to achieve the best setting. Please note that small changes in azimuth make a big difference in the sound.

Save all packing materials, parts, and screws for possible future transport

SITING

FLOOR MOUNTING - Place the deck on a small, light, rigid table, e.g., coffee table. Ensure that the table is level on the floor and not rocking.

WALL MOUNTING - Wall mounting may be preferable when the floor is springy or when there is risk of damage by children or pets. The shelf should be light and rigid, and fully supported by, but not firmly screwed or glued to its brackets.

To allow the lid to open fully, a clearance of 3 inches (7.5 cm.) is required behind the plinth and at least 13 inches (33 cm.) above.

AUDIO CONNECTION

The Goldring Eroica H is a high-output moving-coil cartridge. To play this cartridge properly, you should plug the turntable into a MM (moving magnet) phono stage. Plug the interconnect cable (14) (found in parts bag) into the turntable output connectors (27) matching black to black and red to red. Attach the small ground wire to the thumbscrew connection. Connect the other end of the interconnect cable to the MM (moving magnet) phono input on your receiver or pre-amplifier in the same fashion.

MAINS CONNECTION

Locate the wall transformer. It's in a small white box set into the underside of the packing foam. Plug the small male end of the wall transformer wire into the female receptacle on the power socket for the motor. The power socket for the motor is located on the underside of the turntable near the back. Plug the transformer into the wall. Turn the motor 'ON' (20) and check that the platter (5) spins.

OPERATION

Place a record on the platter and screw on the record clamp (found in parts bag). Simply snug the clamp. Do not over tighten the clamp as damage to your record or turntable may result. Push the mains switch (20) to the 'ON' position. Remove the stylus guard and lift up the tonearm (9) with the cueing lever (7). Position the cartridge stylus tip above the initial groove of the record. Gently lower the cueing lever (7) to lower the tonearm onto the record.

To stop play, lift the cueing lever (7) to raise the tonearm (9) and then move the arm back to the tonearm rest (8). Push the mains switch (20) to 'OFF'.

To play 45 rpm records, simply move the drive belt (3) from the small to the large diameter rim of the stepped motor pulley (2). Do this using the belt-changing tool (19) to avoid touching the belt with your hands. Please note, for singles (7-inch records with a large center hole), you will need to use the 45rpm adaptor. Simply, center the adaptor over the spindle and set it on top of the felt mat. Place the single on the platter and play. Do not use the record clamp with 7-inch records.

MAINTENANCE

The mmf-7.1 is designed for a long operational life. To preserve the appearance of your deck and maintain its performance, you should note the following points:

*** Make sure the stylus guard is on before you begin cleaning ***

PLINTHS - The plinths are constructed from medium density fiberboard, therefore they should not be subjected to extremes of temperature or direct sunlight. The finish may change slightly with age. A damp cloth or soft duster is ideal for cleaning the plinths: polish, particularly wax-based, can be hard to remove.

PLATTER - The acrylic platter can be cleaned with a soft dry lint-free cloth.

MAT - Clean the felt mat with masking tape.

MOTOR - The motor is equipped with self-lubricating bearings. The motor pulley should be cleaned periodically to remove deposits of rubber shed by the belt. Remove the outer platter and belt. Gently clean with a cotton swab or lint-free cloth dampened with isopropyl alcohol.

BELT - The belt should last for many years. The belt can be cleaned at the same time as the pulley. The best way to clean the belt is to pull it gently through a damp cloth. If the turntable is not going to be used for a long period of time, it is advisable to remove the belt from the platter rim to prevent stretching.

OIL - The oil supplied for the main bearing provides life-long protection. If oil is lost from the bearing housing, replace it with a few drops of Mobil 1 or other synthetic oil containing Teflon.

DUST COVER - This can be cleaned using any commercial acrylic or plastic cleaners. The simplest approach is to remove any dust with a damp, lint-free cloth without rubbing and then use a soft duster. Dust covers are more often damaged in cleaning than in use.

STYLUS - Remove the stylus guard. We recommend a dry, vibrating-pad cleaner. Wet cleaners or soft stylus brushes are not recommended.

TECHNICAL SPECIFICATIONS:

Power Supply: 115V/60Hz or 230V/50Hz
Power Absorption: 2VA
Speeds: 33 $\frac{1}{3}$ rpm (manual change to 45 rpm)
Speed deviation: $\pm 0.9\%$
Wow and flutter: $\pm 0.15\%$
Rumble Max: > -70 db
Tracking force: 10 - 30 mN
Effective tonearm length:
9.5 in (24.13cm)
Overhang: .71 inch (18mm)
Platter diameter: 11.81 in (30cm)
Platter weight: 6 lbs (2.7kg)
Dimensions: (W x D x Hw/dust cover closed) 18.25 x 13.25 x 5.5 in
(46.4 x 33.7 x 14 cm)
Weight (including pkg.): 24lbs (10.9 kg)

CARTRIDGE SPECIFICATIONS

Frequency response: 20Hz-20kHz ± 2 dB
Channel balance: 1dB max. @ 1kHz
Channel separation: 25dB @ 1kHz
Sensitivity: 2.5mV ± 1 dB
1kHz @ 5 cm/sec
Static compliance: 18mm/N
Equivalent tip mass: 0.6mg
Vertical tracking angle: 20°
Stylus radius: Gyger II
Stylus type: non-replaceable

Electrical Characteristics

Load resistance: 47Kohms
Load capacitance: 100-500pf
Internal inductance: 0.2mH
Internal resistance: 77ohms

Mechanical Characteristics

Cartridge weight: 5.5g
Fixing centers: 0.5"(12.7mm)
Playing weight: 1.5-2.0g(1.7g nom.)

music hall reserves the right to make technical modifications.

TROUBLESHOOTING

music hall turntables are manufactured to the highest standards and undergo strict quality controls before leaving the factory. If, for some reason your turntable is not working properly, please take a few moments to review this list of potential causes.

THE PLATTER DOESN'T TURN, ALTHOUGH THE DECK IS SWITCHED ON:

- The turntable is not connected to the mains power supply.
- No mains at the socket.
- The belt is not fitted or has slipped off.

NO SIGNAL IN ONE OR BOTH CHANNELS:

- No connection between the turntable and amplifier.
- Phono input not selected at amplifier.
- Poor contact or broken connection.
- Amplifier not switched on.
- Amplifier or speakers defective or muted.
- Cartridge not wired into the head shell
- Loudspeakers not connected.

LOUD HUM ON PHONO INPUT:

- No earth connection from cartridge, tonearm, or audio cable to amplifier.
- Ground loop.
- Turntable too close to one or both speakers.

DISTORTED SOUND FROM ONE OR BOTH CHANNELS:

- Record player connected to wrong input of amplifier.
- MM/MC switch on pre-amp incorrectly set.
- Dust on the stylus.
- Needle or cantilever damaged.
- Wrong speed
- Dirty or over-stretched belt.
- Platter bearing dry, dirty, or damaged.

SERVICE

Should you encounter a problem that you cannot solve, please contact your music hall dealer. Never return a record player without authorization and without safely disassembling it and correctly packing it in the original packaging. Repairs will only be made under warranty if the unit is returned correctly packaged.

PACKING INSTRUCTIONS

Please remove and store the following parts: dust cover (10), anti-skating weight (16), counterweight (6), platter (5), sub-platter (4), and belt (3).

Fit the stylus guard on the cartridge and attach the tonearm locking strap (18) to the tonearm (9). Insert and tighten the transport screws (1). Package the turntable carefully and correctly in its original box.

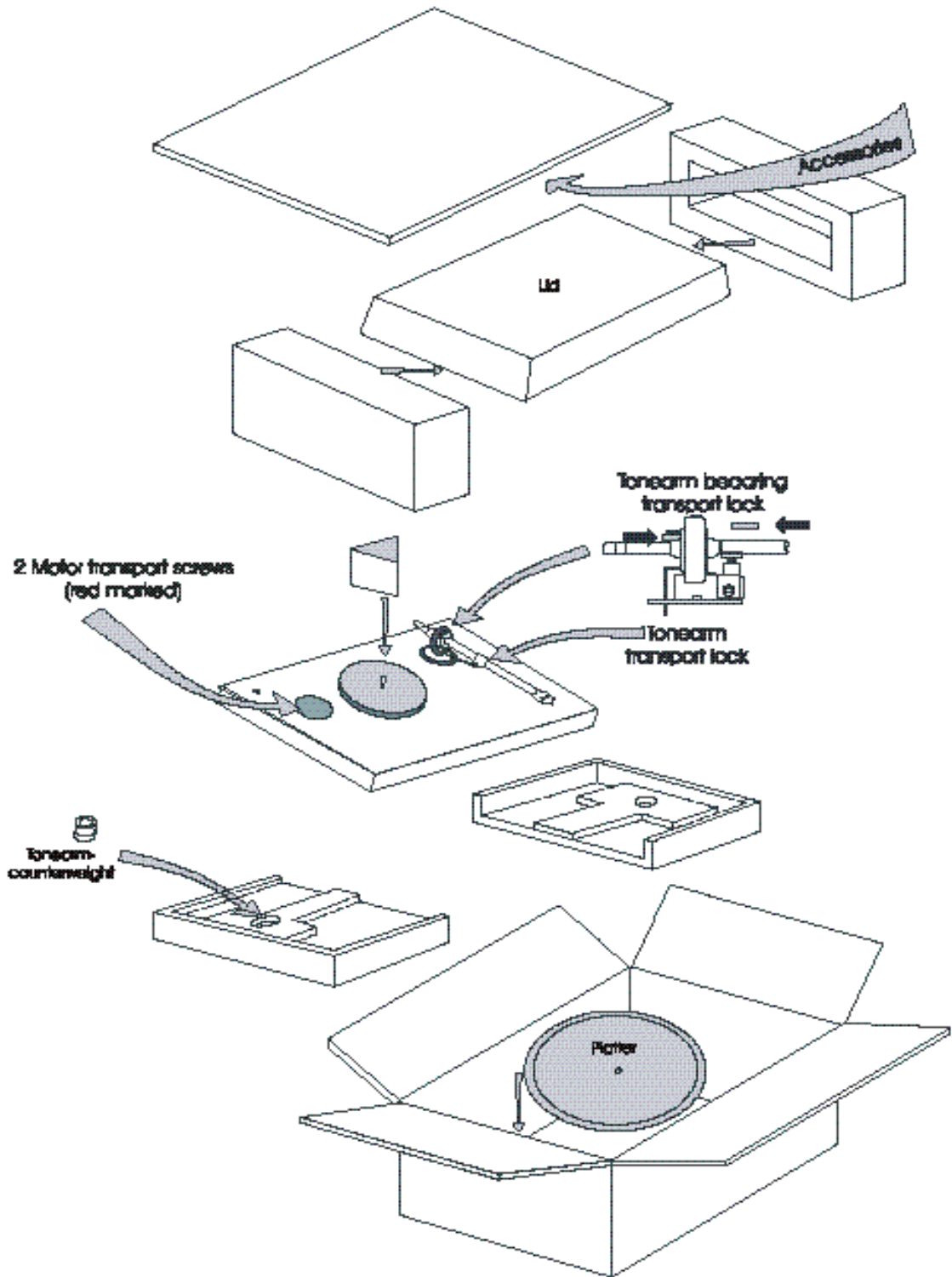

WARRANTY

This entitles you to have the music hall mmf-7.1 repaired free of charge, at our discretion, for one year after the date of purchase, at any authorized music hall Service Center, provided the unit was purchased from an authorized dealer. Your original sales receipt is proof of purchase date. music hall takes no responsibility for defects arising from accident, misuse, abuse, wear and tear, neglect or unauthorized repair and/or adjustment. music hall cannot accept responsibility for damage or loss that occurs during transit.

The warranty does not cover transportation costs.

CLAIMS UNDER WARRANTY

The mmf-7.1 should be packed in the original packing and returned to the dealer from whom it was purchased, or, upon authorization, to a music hall Service Center. It should be sent by a reputable carrier, carriage prepaid. Do not send the turntable via USPS (United States Postal Service). Since no responsibility will be accepted for a unit in transit to the dealer, customer, or authorized service agent, customers are advised to insure against loss, damage, or theft.

FOR FURTHER INFORMATION CONTACT:

music hall
108 Station Road
Great Neck, NY 11023
Tel: 516-487-3663
Fax: 516-773-3891
<http://www.musichallaudio.com>